



# AIRCHARGER®

## INSTALLATION INSTRUCTIONS

### 63-3051

### CHEVROLET / GMC

### 2006 COLORADO / CANYON

### L4-2.8L

**NOTE:** This kit was not designed to fit vehicles with a body lift.

#### TOOLS NEEDED:

- Flat Blade Screwdriver
- Ratchet
- Extension
- 7/32" Socket
- 10mm Socket
- 13mm Socket
- 2.5mm Allen Wrench
- 10mm Wrench
- 13mm Wrench

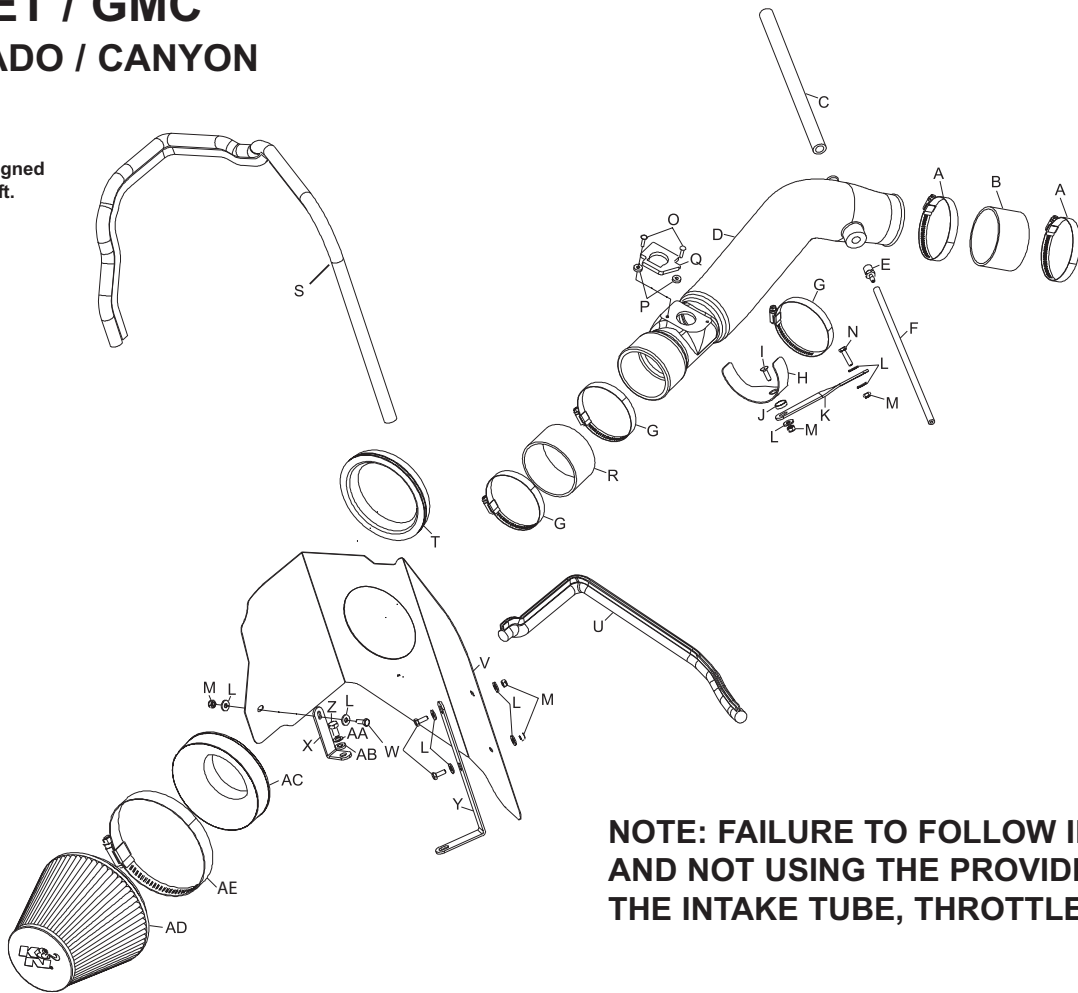

#### PARTS LIST:

Desc.	Part #	QTY.
A	Hose clamp; #48	08601 2
B	hose; 3.0" x 1.75"	08190 1
C	Hose; 1/2" id X 7" L, black silicone	08159 1
D	intake tube (EV)	087163 1
E	Vent; str 3/16" barbed 1/4" npt	080021 1
F	hose; 4mm id x 12"	08147 1
G	Hose clamp; #52	08610 3
H	bracket; saddle	078855 1
I	Bolt; 6mm-1.00 X 16mm, F/H/A	08376 1
J	Washer; conical black nylon	08180 1
K	bracket	010097 1
L	Washer; 1/4" id X 5/8" od, flat	08275 9
M	Nut; 6mm-1.00 nylock	07553 5
N	Bolt; 6mm-1.00 X 25mm	07704 1
O	Bolt; m4-.7 X 16mm, btn hd allen	07793 2
P	Spacer; 500" od X.174" id X.140:thk, nylon	06530 2
Q	Gasket; 1/4" thk poron	09066 1
R	hose; 3.5" id x 2"	08698 1
S	edge trim 44"	102486 1
T	edge trim 19"	102451 1
U	edge trim 26"	102488 1
V	heat shield	074025 1
W	Bolt; 6mm-1.00 X 16mm hex	07703 3
X	Bracket; small "L"	070602 1
Y	Bracket; large "L"	010060 1
Z	Bolt; 8mm-1.25 X 16mm, hex	07844 1
AA	Washer; 8mm wave	08239 1
AB	Washer; 5/16" id X 5/8" od, flat	08276 1
AC	adapter #380	21512 1
AD	filter charger	RF-1048 1
AE	hose clamp #104	08697 1

**NOTE: FAILURE TO FOLLOW INSTALLATION INSTRUCTIONS AND NOT USING THE PROVIDED HARDWARE MAY DAMAGE THE INTAKE TUBE, THROTTLE BODY AND ENGINE.**

#### TO START:

1. Turn the ignition OFF and disconnect the vehicle's negative battery cable.



2. Depress the locking clip on the mass air sensor electrical connection, and then separate the mass air sensor electrical connection.

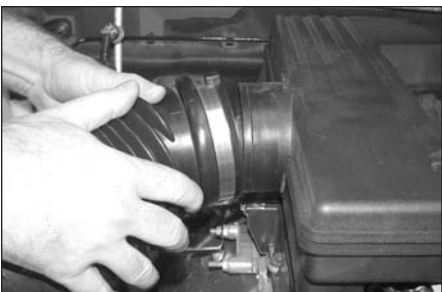

3. Loosen the hose clamp that retains the stock intake tube to the resonator, and then remove the tube from the resonator as shown.

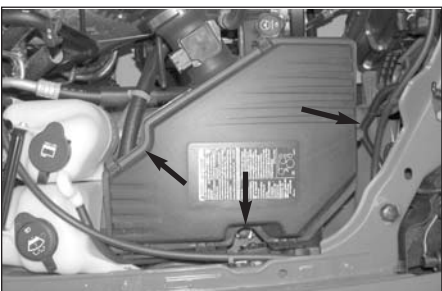

4. Loosen the two air box retaining bolts and one retaining nut.



5. Lift up the air box and remove it from the vehicle.



6. On vehicles equipped with a fuel pressure regulator disconnect the fuel pressure regulator vacuum hose from the fuel pressure regulator as shown.

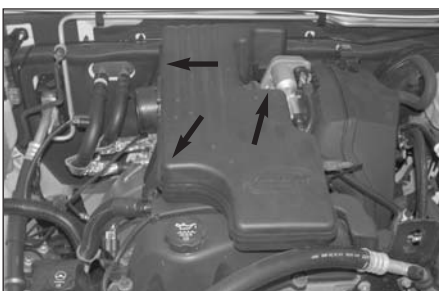

7. Loosen the two bolts that retain the intake resonator to the engine, and then loosen the hose clamp at the throttle body.



8. Remove the intake resonator from the engine as shown.  
**NOTE: Disconnect the crankcase vent hose from the valve cover while removing the resonator from the engine.**



9. Install the silicone hose (08690) onto the throttle body and secure with the provided hose clamp as shown.

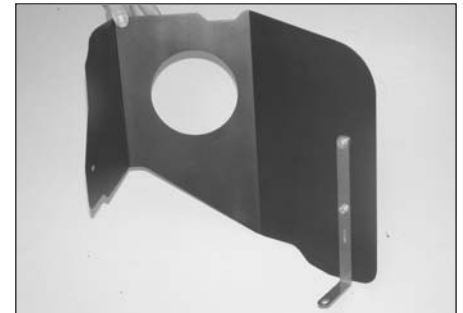

10. Install the "L" bracket (010060) onto the heat shield with the provided hardware as shown.



11. Install the edge trim onto the heat shield as shown.

**NOTE: Start the 26" edge trim at the heat shield mounting bracket on the bottom of the heat shield. Some trimming may be necessary.**



12. Install the edge trim onto the inner hole on the heat shield as shown. Trim if needed.



13. Install the "L" bracket (070602) onto the stock air box-mounting stud using the factory air box-retaining nut.



14. Install the heat shield into the vehicle using the hardware provided and the factory air box retaining nut.

**NOTE: The front heat shield bracket will be secured to the front air box retaining bolt location.**



15. Remove the mass air sensor from the stock air box as shown.

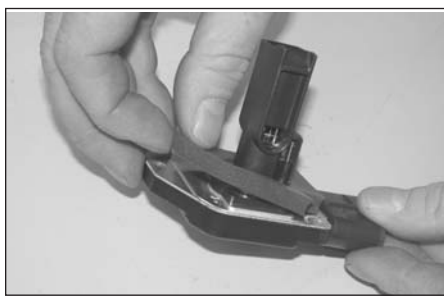

16. Apply provided gasket to mass air sensor as shown.



17. Install the mass air sensor assembly into the K&N intake tube using the provided spacers and button head allen bolts provided.



18. Install the provided 1/4" npt vacuum fitting into the K&N intake tube as shown.



18a. On vehicles not equipped with a fuel pressure regulator vent hose, install the provided npt plug into the K&N intake tube as shown.



19. Remove the clip nut from the forward resonator mount on the valve cover as shown.

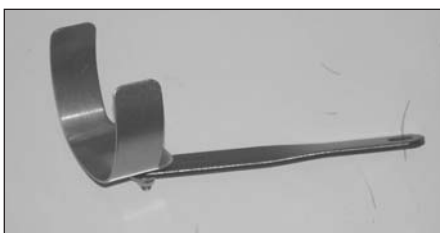

20. Install the saddle clamp onto the tube-mounting bracket with the provided hardware as shown.



21. Install the tube-mounting bracket assembly onto the resonator-mounting tab on the valve cover with the provided hardware as shown.



22. Install the K&N intake tube into the silicone hose at the throttle body and through the heat shield so it rests onto the tube-mounting bracket assembly, then secure with the provided hose clamps.

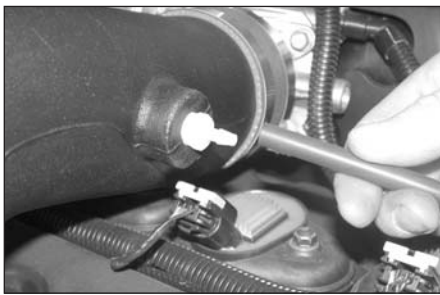

23. On vehicles equipped with a fuel pressure regulator install the provided 4mm vacuum hose onto the fuel pressure regulator, then onto the 1/4" npt vacuum fitting on the K&N intake tube.



24. Install the provided crankcase vent hose onto the valve cover, then onto the K&N intake tube as shown.



25. Install the filter adapter into the Filter charger and secure with the provided hose clamp.



26. Install the silicone hose (08698) onto the filter charger assembly as shown.



27. Install the filter charger assembly onto the K&N intake tube and secure with the provided hose clamp.



28. Reconnect the Mass Air sensor electrical connection.



29. Reconnect the vehicle's negative battery cable. Double check to make sure everything is tight and properly positioned before starting the vehicle.

30. It will be necessary for all Aircharger's to be checked periodically for realignment, clearance and tightening of all connections. Failure to follow the above instructions or proper maintenance may void warranty.

#### ROAD TESTING:

1. Start the engine with the transmission in neutral or park, and the parking brake engaged. Listen for air leaks or odd noises. For air leaks secure hoses and connections. For odd noises, find cause and repair before proceeding. This kit will function identically to the factory system except for being louder and much more responsive.

2. Test drive the vehicle. Listen for odd noises or rattles and fix as necessary.

3. If road test is fine, you can now enjoy the added power and performance from your kit.

4. K&N suggests checking the Filtercharger element periodically for excessive dirt build-up. When the element becomes covered in dirt (or once a year), service it according to the instructions on the Recharger service kit, part number 99-5050 or 99-5000.